

MX-5 NC remote repair

Words: Bob de Bont

Has the remote for your NC stopped working. Follow these steps to repair it.

Most problems fall into one of two categories: the battery is flat or the remote loses registration.

To identify which is the problem, press any button on the remote and confirm the red light flashes.

- » no red light indicates a flat battery
- » if the red light flashes, the remote has lost connection with the car and requires reprogramming.

Another common problem is where the remote unlocks the doors but not the boot.

How to replace the battery in an NC remote

The replacement battery you need is a **CR1620**.

1. Insert a small screwdriver into the slot and push the tab to remove the key from the transmitter

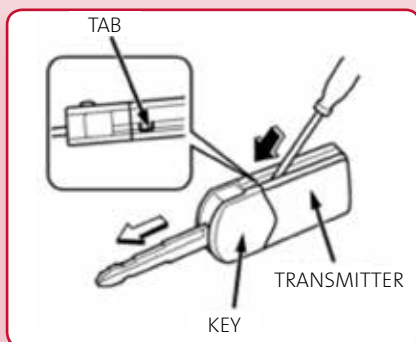

2. Insert a small screwdriver into the slot and gently twist to pry open the transmitter and access the battery

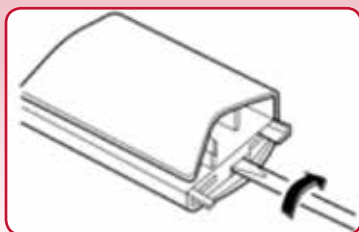

3. Remove the battery

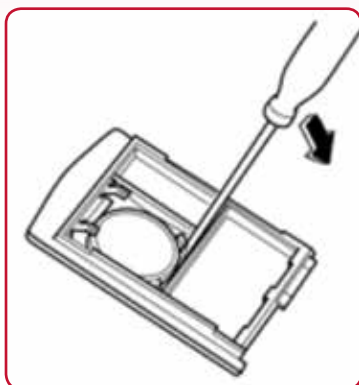

4. Insert the new battery and reassemble the fob in the reverse order
5. Confirm the red light flashes when a button is pressed

How to program an NC remote

Note: this procedure won't work if you have disabled the "key in ignition - door open" warning chime.

If this chime is disabled, you must re-enabled it before commencing the reprogramming process.

Carry out the following steps:

1. Remove key from ignition
2. Close all doors
3. Open driver's door
4. Perform following steps **within 24 seconds**
 - A. Turn ignition switch ON and back to LOCK position three times
 - B. Close and open the driver's door three times (or press the courtesy light switch three times)
 - C. Door locks should lock and unlock automatically. If they don't, wait 40 seconds and repeat procedure starting at Step 1
5. On each keyless remote to be programmed, press the UNLOCK button **twice**. The door locks should lock and unlock after each remote is programmed. If the door locks do not lock and unlock, proceed as follows:
 - » Close and open the driver's door once. The door should lock and unlock twice
 - » If the door locks do not lock and unlock, start the procedure over with Step 3
6. Exit the vehicle and test remote(s)

Remote unlocks the doors but not the boot

The most common reason for the boot release button not to work is because the "boot release lockout button" is engaged.

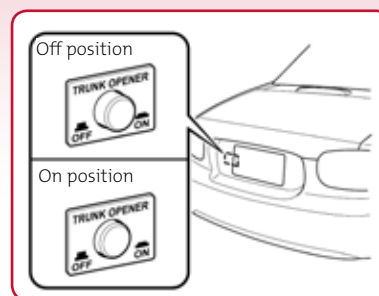

If the remote boot release button doesn't work, try the boot release button located beside the bonnet release lever in the cab, or try another remote.

If neither button releases the boot, check the boot release lockout button. If one or other release button does work then something is amiss with the boot release system.

If this is the case, we recommend you contact your Mazda workshop. ■

■ **Please note:** All "Tech Talk" information is provided as a guide only. All work is carried out at the owner's risk.